

Operator's Manual



CERTIFIED
ISO 9001:2000



U4466 Series

English

ECN # ECN-4367, Effective Date 1/10, MF-060, Rev A

Madison Company
27 Business Park Drive Branford, CT 06405
(203) 488-4477 • Fax (203) 481-5036
E-mail: info@madisonco.com
www.madisonco.com

Madison Europe
Ninaberlaan 83
NL-7447 AC Hellendoorn • The Netherlands
+ 31 (0) 548 659 034 • Fax: + 31 (0) 548 659 010
E-mail: Madison@eurodev.com

U4466-2000

U4466-3000

U4466-5000

U4466-6400

U4466-9400

Table of Contents

<i>Warranty</i>	3
<i>Introducing</i>	4
<i>Understanding Ultrasonics</i>	5
<i>Mounting</i>	7-9
<i>Hazardous Mounting</i>	9
<i>Wiring</i>	10-13
<i>Sensor Adjustment</i>	14-16
<i>Programming</i>	16-25
<i>Control</i>	16
<i>Filtering</i>	19
<i>Calibration</i>	20
<i>Analog Scaling</i>	22
<i>Trip Point Control</i>	23
<i>Serial (RS-232) Operation</i>	25
<i>Specifications & Dimensions</i>	26-32
<i>Certificate of Compliance</i>	33-35



• Warranty and Warranty Restrictions

Madison warrants its products to be free from defects of material and workmanship and will, without charge, replace or repair any equipment found defective upon inspection at its factory, provided the equipment has been returned, transportation prepaid, within 18 months from date of shipment from factory.

THE FOREGOING WARRANTY IS IN LIEU OF AND EXCLUDES ALL OTHER WARRANTIES NOT EXPRESSLY SET FORTH HEREIN, WHETHER EXPRESSED OR IMPLIED BY OPERATION OF LAW OR OTHERWISE INCLUDING BUT NOT LIMITED TO ANY IMPLIED WARRANTIES OF MERCHANTABILITY OR FITNESS FOR A PARTICULAR PURPOSE.

No representation or warranty, express or implied, made by any sales representative, distributor, or other agent or representative of Madison which is not specifically set forth herein shall be binding upon Madison. Madison shall not be liable for any incidental or consequential damages, losses or expenses directly or indirectly arising from the sale, handling, improper application or use of the goods or from any other cause relating thereto and Madison's liability hereunder, in any case, is expressly limited to the repair or replacement (at Madison's option) of goods.

Warranty is specifically at the factory. Any on site service will be provided at the sole expense of the Purchaser at standard field service rates.

All associated equipment must be protected by properly rated electronic/ electrical protection devices. Madison shall not be liable for any damage due to improper engineering or installation by the purchaser or third parties. Proper installation, operation and maintenance of the product becomes the responsibility of the user upon receipt of the product.

Returns and allowances must be authorized by Madison in advance. Madison will assign a Return Material Authorization (RMA) number which must appear on all related papers and the outside of the shipping carton. All returns are subject to the final review by Madison. Returns are subject to restocking charges as determined by Madison's "Credit Return Policy".

• **Introducing**

<u>Model</u>	<u>Operating Range</u>	<u>Available Outputs</u>
U4466-5000's	4 to 79 in.	4-20 mA, 4-20 mA + (2) NPN Trip Points (300 mA max), 0-2.5 V / 0-5 V
U4466-2000's	1 to 25 ft.	Solid State Relay (U4466-2002 only; 130 mA max), 4-20 mA, 4-20 mA + (2) NPN Trip Points (300 mA max)
U4466-6400's	1 to 30 ft.	0-2.5 V / 0-5 V
U4466-3100's	1.25 to 35 ft.	4-20 mA, 4-20 mA + (2) NPN Trip Points (300 mA max)
U4466-9400's	0.5 to 35 ft.	4-20 mA, 4-20 mA + (2) NPN Trip Points (300 mA max), 0-2.5 V / 0-5 V
U4466-3400's	1.25 to 50 ft.	4-20 mA, 4-20 mA + (2) NPN Trip Points (300 mA max)

The U4466 series of self-contained ultrasonic sensors are designed for a wide range of industrial automation applications. The analog output models come from the factory with the span scaled to match the operating range. The sensors are programmed via an RST module or potentiometers (only the U4466-2002 and U4466-2003 are equipped with potentiometers). The RST programming module is required to access and adjust sensor parameters such as sensitivity and analog span, and comes in either a USB interface (RST-3001) or RS-232 interface (RST-2001A). Both models include a user-friendly Windows based software program. The U4466 sensors also have internal temperature compensation for increased accuracy under varying environmental conditions. The sensors are housed in PC/PET, PVC, or UV resistant ABS to seal out moisture and are resistant to many chemicals.

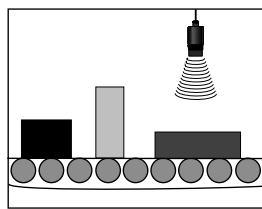

Product Dimension
and Sorting

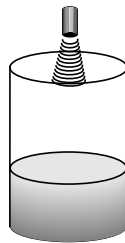

Tank Level
Elevation

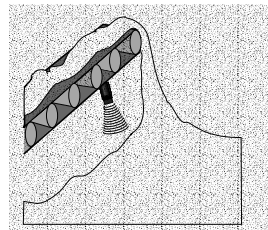

Conveyor Belt
Monitoring

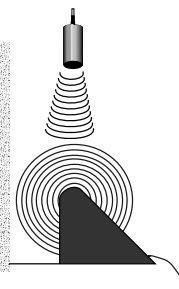

Measurement of
Roll Diameter

• **Understanding Ultrasonics**

Ultrasonic sensors measure distance using a transducer to send out ultrasonic bursts. Each burst contains a series of 1-20 pulsed sound waves that emit in the shape of a cone, reflect off the target, and are received by the sensor. The time required for the sound burst to travel to and from the target is converted into a distance measurement by the sensor.

Ultrasonic sensing is affected by several factors including the target surface, distance, size, and angle. The following considerations will help ensure the best possible target conditions.

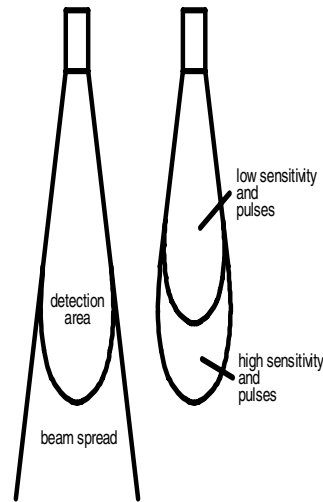

Surface

The ideal target surface is hard and smooth and perpendicular to the face of the transducer. This surface will reflect a greater amount of signal than a soft, sound wave absorbent surface. A target with poor sound wave reflection characteristics will reduce the operating distance of the sensor and decrease its accuracy.

<p>GOOD</p> <p>surface</p> <p>BETTER</p>	<p>GOOD</p> <p>distance</p> <p>BETTER</p>	<p>GOOD</p> <p>size</p> <p>BETTER</p>	<p>INCORRECT</p> <p>angle</p> <p>CORRECT</p>
---	--	--	---

Distance

The shorter the distance from the sensor to an object, the stronger the returning echo will be. Therefore, as the distance increases, the object requires better reflective characteristics to return a sufficient echo.

Size

A large object will have a greater surface area to reflect the signal than a small one, therefore, a large target will be detected at a greater distance than a small target. The surface area recognized as the target is generally the portion closest to the sensor.

Angle

The inclination of the object's surface facing the ultrasonic sensor affects the reflectivity of the object. The portion perpendicular to the sensor returns the echo. If the entire surface is at a great enough angle, the signal will be reflected away from the sensor and no echo will be detected. Generally a target at an angle greater than 5 degrees off perpendicular will not be detected.

Environmental Conditions

Temperature, humidity, gases, dust, and pressure may also affect the sensor's performance. Madison ultrasonic sensors automatically compensate for many of these conditions. However, these conditions can degrade the sensor performance enough it may be necessary to use a longer-range sensor than normal conditions would require.

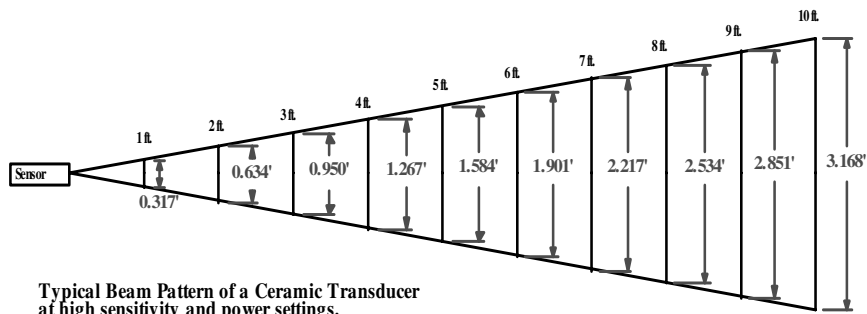

- **Mounting**

General Mounting

Mounting is a critical factor for successful operation of an ultrasonic sensor. The U4466 sensors have the following mounting options available: Surface mount (only available on 2000 series), NPT mount, 150# flange mount, or sanitary tri-clamp mount.

Direct sunlight can affect the accuracy of the sensor when the temperature compensation is activated. The radiant heat can cause the sensor to over compensate for ambient temperature changes. If the sensor is used outdoors, it should be shaded from direct sunlight.

If the sensor is mounted in an area where extreme dirt may accumulate, or product may cake on the sensor, periodic inspection and cleaning is recommended. Cleaning can be accomplished with a mild detergent and water. High power sprayers are not recommended, however if one is used avoid direct blasts around the O-ring seal on surface mount models.

Always mount above the highest anticipated target level by at least the published minimum blanking distance. It is always advisable to allow as much headroom as possible to keep the target from entering the blanking area. **If a target enters into the blanking area, error in the detection will occur.** Install so that there is a clear sound path perpendicular to the target surface. If the target is more than 3°-5° off perpendicular, it may not be detected. The beam angle is approximately 9° off axis. To avoid false echoes, install so that the beam will not intersect vessel fill spouts*, rough vessel walls, ladders...etc. (*if heavy foam is expected, it is often helpful to mount near a fill spout where the foam is dispersed.)

NPT and Flange Mounting (read general mounting before continuing)

Mount the sensor in a coupler or half coupler welded to the top of tank. The coupling should extend through the top of tank. The coupler must be aligned perpendicular to the target level. **Screw sensor in only hand tight.** Soft gasket material is recommended with flange mounting.

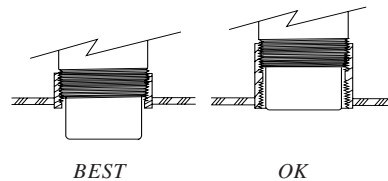

Stand Pipe Mounting (read general mounting before continuing)

Stand pipes are used to provide tank headroom when the target is expected to come closer to the sensor face than the minimum blanking distance. Using a stand pipe can degrade the performance of the sensor. The stand pipe should be installed perpendicular to the target. The pipe must have smooth walls (no joints) and no burrs or obstructions on the end of the pipe. If possible, cut the end of the pipe at a 10°-45° angle (see drawing). Use the largest diameter pipe and shortest length possible. As a general rule the diameter of the pipe should be 1/2 the length. The pipe ID must remain the same through it's entire length.

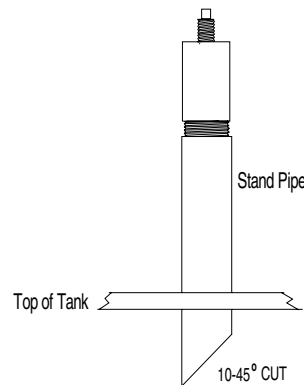

Stilling Well Mounting (read general mounting before continuing)

Stilling wells provide access to difficult areas and help eliminate problems with foam. The pipe must have smooth walls (no burrs or joints). The sound waves from the sensor concentrate and propagate down the inside walls of the tube. Any irregularities on the tube walls may produce echo returns and cause false readings. Stilling wells are limited to liquid targets that will not leave deposits on the tube walls. Because the sound waves stay concentrated inside the tube, it is usually necessary to reduce the sensors pulses and sensitivity settings. **A vent hole must be provided at the top of the tube.** Keep the vent hole inside the blanking distance.

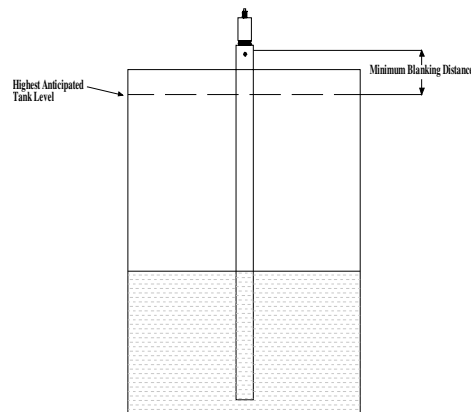

• Hazardous Mounting

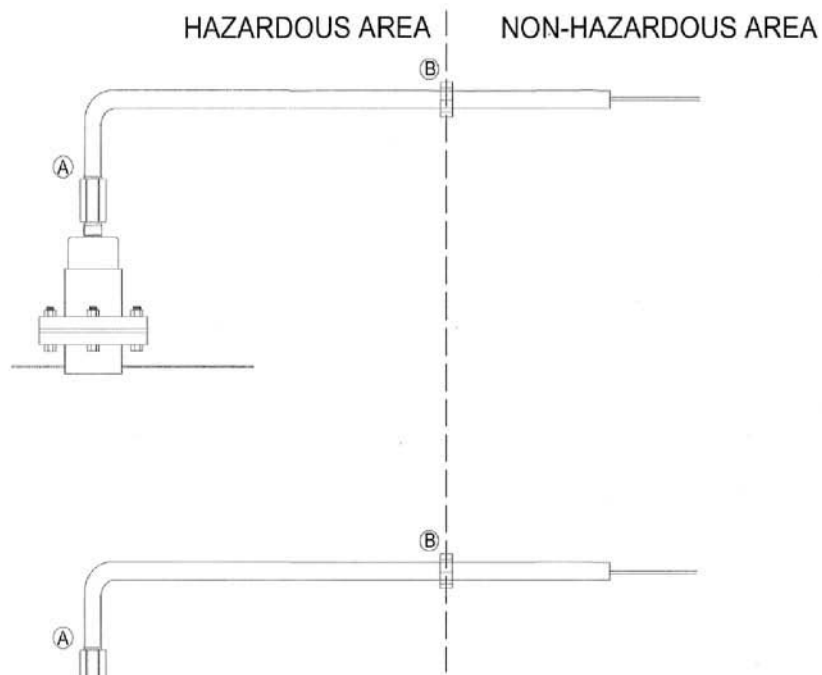

- Install in accordance with Section 18 of the CEC or Article 500 of the NEC.
- CSA listed or NRTL/UL listed conduit seal at location A & B.
- The cable is potted into the sensor and runs continuously from the sensor through the Hazardous area and into the Non-Hazardous area.
- Electrical equipment connected to associated apparatus should not generate more than 250 V rms.
- Tampering or replacement with non-factory components may adversely affect the safe use of the system.
- **DO NOT DISCONNECT WHILE CIRCUIT IS ALIVE UNLESS AREA IS KNOWN TO BE NON-HAZARDOUS**

• **Wiring**

The U4466 series sensors are equipped with either a terminal wiring strip (surface mount only), or a multi conductor cable or micro connector (see diagrams below). It is recommended that the sensors are powered from 24 VDC. A quality regulated linear power supply is recommended. Only high quality switching power supplies should be used.

The CLOCK SYNCHRONIZATION is used when multiple sensors are located in close proximity. When a connection is made between the clock sync. terminals (green wires) of two or more sensors, the sensors will transmit at the same time. This will help prevent cross talk between sensors in most situations. The sensors must have a common ground for the clock synchronization to function.

The DIGITAL output is used to interface with an Madison digital readout, part no. ACC-1007 or ACC-1008 (optional, consult factory). This output is a 0-5 V signal that goes high when the sensor transmits, and is pulled low when the sensor received the echo. The time interval the signal is high corresponds to the total time of flight for the transmitted sound wave. Using the speed of sound, the distance to the target can be determined. In order for the digital readout to function, it must have a common ground with the sensor.

**Trip Point/Relay Output (U4466-2xx2)
6-Conductor Cable**

- RED +24VDC
- BLACK Ground
- GREEN Clock Sync.
- WHITE Digital Output
- ORANGE Relay
- BLUE Relay

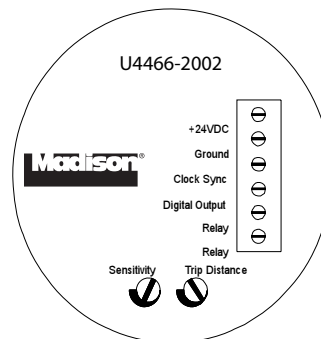

4-20mA Output

Models equipped with an **Isolated 4-20 mA** analog output require power to be supplied to the 4-20mA circuit in order for it to operate. This output may operate with PLCs, digital displays, or other analog devices. If the equipment the sensor is interfaced with is current sinking, the sensor can be jumpered to provide a current source. Wiring for current sourcing and isolated outputs is indicated below.

NOTE: For models equipped with an isolated 4-20 mA output. If the mA circuit power (orange) is being sourced by the main sensor power (red), then the output may be unstable while communicating through the RST programming module.

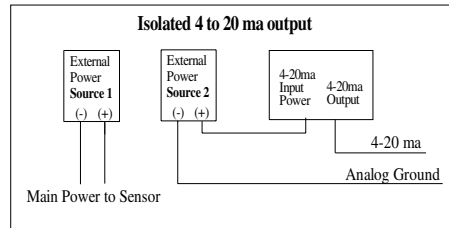
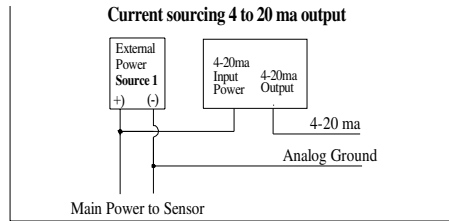

Isolated 4-20 mA Output (U4466-2003, 21x3 & 31x3)

6-Conductor Cable

- RED +24 VDC
- BLACK Ground
- GREEN Clock Sync.
- WHITE Digital Output
- ORANGE Analog Circuit Power (+24 VDC)
- BLUE 4-20 mA Output



4-20 mA Output (U4466-24x3, 34x3, 5xx3, 64x3 & 94x3)

3-Conductor Cable

- RED +24 VDC
- BLACK Ground
- White 4-20 mA Output

4-20 mA with 2-NPN Trip Points (U4466-5xx5, 24x5, 34x5, 64x5 & 94x5)

5-Conductor Cable

- RED +24 VDC
- BLACK Ground
- ORANGE 4-20 mA Output
- WHITE NPN Output 1
- GREEN NPN Output 2

U4466-xxx5-M

- 1 Brown +24VDC
- 2 White NPN 1
- 3 Blue Ground
- 4 Black mA+
- 5 Grey NPN 2

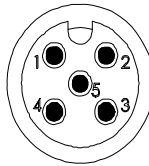

4-20 mA with 2-NPN Trip Points (U4466-2xx5 & 3xx5)

6-Conductor Cable

- RED +24 VDC
- BLACK Ground
- ORANGE 4-20 mA Output
- BLUE NPN Output 1
- WHITE NPN Output 2
- GREEN Clock Sync

0-2.5/0-5VDC (U4466-51x9, 6429 & 9429)

5-Conductor Cable

- RED +24 VDC
- BLACK Ground
- WHITE 0-5/0-2.5Vdc Output
- GREEN Analog Ground
- ORANGE Excitation

U4466-6x29-M

1	Brown	+24VDC
2	White	Vout
3	Blue	Ground
4	Black	Analog Gnd
5	Grey	Excitation

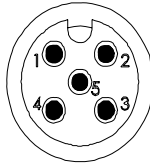

0-2.5/0-5VDC with RS-232 (U4466-5xx9S, 6429S & 9429S)

U4466-xxx9S- C

Red	+24VDC
Black	Ground
Orange	Excitation
White	Voltage Out
Green	Analog Gnd
Brown	RS-232 Gnd
Yellow	RS-232 TX
Blue	RS-232 RX

U4466-xxx9S-M

1	White	Vout
2	Brown	+24VDC
3	Green	Analog Ground
4	Yellow	RS-232 TX
5	Gray	RS-232 GND
6	Pink	RS-232 RX
7	Blue	Ground
8	Red	Excitation

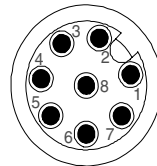

• RST Wiring

The U4466 series sensors are fully programmable using an external RST programming module that acts as an interface between the sensor and a personal computer. The RST programming module comes in two varieties:

- RST-2001A utilizes a 9 pin serial interface.
- RST-3001 utilizes a USB interface.

15 - 28 VDC (500 mA min.) is supplied to the RST programming module through a 2-pin Phoenix connector. The sensor's VDC + and VDC Common are then connected to the programming module through a second 2-pin Phoenix connector. Applying power to the RST module will power the sensor. The sensor should start audibly "ticking" when power is applied. The operating parameters of the sensor can then be adjusted using the included Windows based software.

To connect the RST programming module, follow the connection diagram below. A straight through serial cable should be used with the RST-2001A.

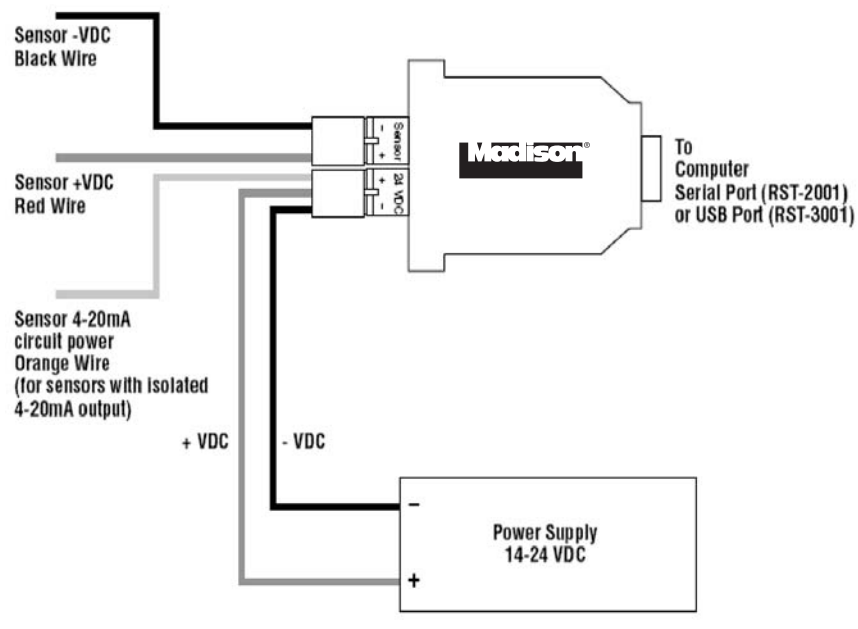

• Installing Utility Program

The utility program used for adjusting the sensor's settings is supplied on a mini CD. The installation utility should autorun when the mini CD is inserted into a CDROM drive. The installation process will prompt you as needed to complete the installation. This will load the utility program to your hard drive and create a link under the Windows Start Menu. If the installation program does not autorun when the CD is inserted, run the Windows Installer Package titled, "Setup" on the CD. The setup program can be run from the Windows "START" menu "RUN" option by entering the file location and name, or by going to Windows Explorer, locating the file and double clicking on the file. Either method will run the executable installation file.

Once the installation is complete, start the utility program from the Windows Start Menu or by double clicking on the desktop icon. The utility program has several buttons and windows to view and enter information. The lower right corner of the screen contains a window indicating the communication status of the sensor and computer. It will indicate "ERROR No Communication", or "Communication OK". If an error is indicated, click on the "Communications" button to change the communication option that matches the RST's connection to the computer. The options are "Com Port 1", "Com Port 2", or "USB". After changing com ports, allow a moment for the communication to be established while watching the status window to indicate "Communication OK". If communication is not established, check the wiring, cable connection to the computer, and ensure that power is supplied to the RST module. If you are using the RST-2001A serial interface module and communication cannot be established, then you may have a computer communications port conflict. If devices drivers have been loaded on your computer for other devices that use a com port (such as a serial mouse), then the drivers must be removed or disabled before another device (such as an ultrasonic sensor and RST unit) will be able to communicate through the com port on the computer.

After communication is established, all of the windows in the utility program should automatically be populated with the current sensor settings. If not, use the "Receive" button to load the current sensor setting into the utility program. Making changes to the sensor settings is accomplished by clicking in

the appropriate window, entering the desired value, and then clicking the "Send" button. The "Reset" button will load the factory settings into the sensor. The "File" button is used to read or write complete sensor settings to the computer. The program is closed by clicking on the "Exit" button.

There are five windows that indicate real time sensor status for the following:

- Distance
- Analog Output
- Temperature
- Communication Status
- Signal Strength (only visible when operating in AutoSense mode, which is represented by a "Gain Control" setting of 1).

The "distance" reading indicates the distance from the sensor face to the target being detected. "Analog Output" status indicates the calculated value of the analog output signal based on the target distance and the analog settings. "Communication" indicates the status of communication between the sensor and the computer. The "Signal Strength" window indicates how well the sensor is detecting the target when operating in AutoSense mode. The Signal Strength scales from 0 to 7. A value of 0 indicates the sensor is easily detecting the target, while a value of 7 indicates the sensor is not able to detect a target. "AutoSense Disabled" indicates the sensor is in manual mode (Gain Control settings of 0, 2, or 3).

Sensor Programming

The programming options for the sensor can be broken into five groups; **Control, Filtering, Calibration, Analog Scaling, and Trip Point Control**. The programming parameters will vary depending on output type, either analog, or trip point.

Control

Units: allows the user to select the unit of measure for screen programming. The options are feet, inches and millimeters where 1= ft., 2 = in., and 3 = mm.

Blanking: sets a dead band distance in front of the sensor. When the sensor transmits the ultrasonic pulse, the transducer does not stop vibrating instantaneously. It takes about 1-3 milliseconds to send the burst and then ring-down, depending on the number of pulses sent in the burst. Any echoes that return before the sensor finishes transmitting can not be received by the sensor. This is the reason for the minimum distance specification. The minimum setting for the 2000 series is 1 foot. The 3000 series has a minimum blanking of 1.25 feet, 5000 series is 4 inches, 6000 series is 1 foot, and 9000 series is 7 inches.

The blanking may be set at distances greater than the minimum. There are instances when an object close to the sensor is being detected, preventing the sensor from detecting the intended target beyond. Setting the blanking distance greater than the unwanted object can help eliminate the interference. Care must be taken that the intended target does not come closer to the sensor than the blanking distance. **If the target is closer than the blanking distance, errors in the distance measurement will occur.**

Sensitivity: controls the gain or amplification setting of the sensor. This setting can be adjusted using the potentiometer on the back of the sensor (if equipped with the potentiometer), or in the software using the utility program. The Sensitivity Select provides the option to change between potentiometer and software control. If the sensor is not equipped with a potentiometer, the setting should be set for software control. Those models with a potentiometer use a single turn pot. Turning clockwise increases the sensitivity.

In the utility program, the sensitivity is expressed as a percentage with options of 0 to 100%. The ideal setting is as low as possible while still allowing reliable tracking of the target. The lower the sensitivity setting, the less likely the sensor will be affected by ambient noise, either electrical or acoustical. A low setting will help reduce the possibility of detecting unwanted echoes reflected from objects in the area near the detection pattern of the sensor.

The sound wave signals from the sensor are affected by temperature. At warmer temperatures the sensor will be less sensitive than at cooler temperatures. If a sensor is set up when the temperature is cool, and the temperature is expected to increase, the sensitivity level should be increased 10 to 20% after determining the ideal setting at the present temperature. This will help offset the decreased sensitivity as the temperature rises.

The sensitivity can be used to eliminate the detection of unwanted echoes. If the sensor periodically outputs a distance that is closer than the target,

reducing the sensitivity will help eliminate the detection of the unwanted echoes and noise.

Sensitivity Select: provides the option to change between potentiometer and software control of the sensitivity adjustment. Setting to 0 will allow potentiometer adjustment, while setting to 1 will use the program setting. This setting should be set to 0 only if the sensor is equipped with a potentiometer.

Pulses: control the number of ultrasonic waves sent in each burst. The greater the number of pulses the stronger the transmitted signal. For most open air applications this should be set between 15 and 20. For small enclosed areas the number of pulses may need to be reduced to limit the amount of energy transmitted into the area. Targets with good reflective characteristics do not require as high a setting as those targets with poor reflective characteristics.

The range of adjustment is from 0-20 pulses. If this parameter is set to 0, the sensor will not transmit. This is useful to troubleshoot problem applications. When set to 0, the detected distance should go to the maximum operating range of the sensor as set in **Max Distance**. If the distance reading does not go to the maximum distance, this is a good indication there is an electrical or acoustical noise source present.

Gain Control:

- 0 = Manual Mode (run at programmed sensitivity & pulses)
- 1 = Autosense (see description below)
- 2 = Hard-Target (Ramps the gain slower than manual mode)
- 3 = Soft-Target (ramps the gain faster than manual mode)

The most reliable distance readings are obtained when the minimum transmitted energy (pulses) and sensitivities are used. To aid the user in setup and accuracy, the **AutoSense** feature is available in this sensor. AutoSense automatically adjusts the **sensitivity** and **pulses** to a minimal setting based on the signal strength of the return echo. If AutoSense is activated, the maximum sensitivity and pulses are limited by the setting selected in those fields. For example, if the sensitivity is set to 65, then the maximum sensitivity the AutoSense feature can use is 65. If the potentiometer is activated, the sensitivity will be limited by the potentiometer setting. The pulses are also limited. AutoSense is most effective when used on liquid targets, and is usually not recommended with bulk solids.

Filtering

The filtering settings in the sensor help the user to determine what echoes qualify as legitimate targets. There are four parameters that affect the filtering: Average, Window, Out of Range Samples, and Sample Rate.

Average: defines the number of sensor readings (samples of a target) that will be averaged together by the sensor. Each qualified sample is placed into a First-In First-Out (FIFO) buffer and averaged with the previous samples to generate a steady output. A qualified sample is one that falls within the boundaries set in the WINDOW parameter. The higher the number of samples averaged, the greater the smoothing effect of the measurement. A higher average setting will result in a slower response to changes in measurement. A fast moving target may require a lower average setting.

Window: specifies a range in which target readings will be accepted. Any reading that falls within this range is accepted as a valid target and is figured into the averaging buffer. The acceptance window is **plus** or **minus** the specified distance from the present distance reading. If the sensor is detecting a target at 5 ft. and the WINDOW is set at 1 ft., then any target detected between 4 ft. and 6 ft. will be accepted.

Out of Range Samples: indicates the number of consecutive readings (samples) outside the Window that will need to be detected before the sensor recognizes them as legitimate targets. Suppose the **Window** is set at 1 ft. and the **Out Of Range Samples** is set to 10. The current distance reading is at 5 ft. If a new target entered the detection area of the sensor at a distance less than 4 ft. or the target suddenly moved to a distance greater than 6 ft., the target would need to be present in the new location long enough for the sensor to receive 10 consecutive samples outside the original window before the sensor would recognize the reading as a target. If the target were outside the window for only 9 samples, then returned to the original 5 ft. distance, the sensor would retain the 5 ft. distance reading. The sudden change, or the new target would be ignored.

Sample Rate: adjusts the speed of the sensor readings. The sample rate is expressed in Hertz. Options allow for rates from 1 to 50 Hz. **The sample rate is limited by the Max Distance setting.** The longer the maximum distance setting,



the lower the maximum sample rate can be set. A higher sample rate will cause a more rapid response, but may decrease the stability of the measurement. Lowering the sample rate will decrease the chance for multiple echos. Note: for slow moving levels a sample rate of 4 is appropriate.

View Noise Level (view only value): indicates the number of echoes being detected by the sensor. Noise levels in excess of 20 to 30 is an indication that noise sources are present and may interfere with the sensor operation. Reducing the sensitivity may help reduce the amount of noise detected.

Set Noise Threshold: controls a filter that will eliminate interference from temporary high noise levels. If a noise level exceeds this threshold, the sensor will maintain the last measurement before the high noise level was detected. The measurement will be maintained until the noise level drops below the threshold setting. Sources of noise could be pneumatic equipment, machine presses, shears, or other manufacturing equipment.

Calibration (no adjustments needed for most applications)

The sensor can be adjusted so the detected distance is equal to the measured distance. There are various atmospheric conditions that will affect the speed of sound such as temperature, humidity, pressure, and chemical vapors. For most accurate measurement the sensor will need to be calibrated in the environments in which it will be operating. If the sensor is in an environment where the temperature will be cycling, the temperature compensation should be turned on or an external means of temperature compensation should be implemented. When the temperature compensation is used, it should be turned on before the sensor is calibrated.

Multiplier: is used to bring the detected distance in line with the physical measurement. The speed of sound is not constant through all environments and temperatures. The multiplier enables the user to compensate for the change in the speed of sound for a variety of environments. To determine the multiplier to setting, measure from the face of the transducer to the intended target. Divide the measured distance by the distance reading in the sensor software and enter resulting value in the multiplier. For example, a target is placed 2.5 ft. from the sensors face; the displayed distance is 2.68 ft. The multiplier is $2.5/2.68 = 0.9328$. This value is entered into the multiplier setting.

Offset: adjusts the zero point of the sensor. When the offset is set to 0, the electrical zero of the sensor is approximately 0.86 in. behind the face of the transducer. The factory setting of 16 adjusts the zero point to the leading edge of the transducer. The options for this setting are 0-255. The number represented is equal to counts of the microprocessor. Each count of the processor is approximately equal to 0.054 in.

Temp_Comp: turns the temperature compensation ON or OFF. The speed of sound through air changes about 0.18% for every degree Celsius. If temperature changes are experienced, the distance measurement will vary according to this percentage. Using the internal temperature compensation will reduce the effects of temperature changes by 50% or more. The sensor will need to be calibrated after switching the temperature compensation on or off. Follow the instructions provided in the Multiplier section.

NOTE: If the internal temperature compensation is used, care must be taken that the sensor is not exposed to direct sun light. The radiant heat of the sun can heat the sensor above the ambient temperature causing the sensor to over compensate for temperature changes.

External Temp_Comp: a correction factor for the change in the temperature compensation may be achieved by using an external temperature probe in conjunction with a PLC and applying a correction formula to the sensor output. In some circumstances this may achieve better results than using the internal temperature compensation.

The formula for the change in the speed of sound is:

$$((T1 - T2 + 273)/273)^{0.5}$$

where: $T1$ = present temperature in °C,

$T2$ = temperature when sensor was calibrated.

There are two approaches for using the correction formula. One uses the factory calibration with the sensor's multiplier set to 1.00. The factory calibration is based on a temperature of 25°C. Therefore, $T2$ will equal 25. The second approach is to calibrate the sensor as outlined in the multiplier section then apply the temperature correction. In this case, $T2$ becomes the temperature at the time of calibration.

Analog Scaling

Scaling of the analog signal is accomplished using the **20mA / 2.5(5)V Set Point** and the **4mA / 0V Set Point** parameters. Scaling the output is accomplished by entering a distance value for the 4 mA / 0V endpoint and the 20mA / 2.5(5)V endpoint. The analog output will be scaled between the distance point entered in each of these settings. The output can be inverted by interchanging the values in each parameter. If the detected target is outside the scaling range, the sensor will output either full scale or minimum scale depending on the location of the target.

For example, the 20 mA distance is set to 2 ft., and the 4 mA distance is set to 8 ft. If the target is closer than 2 ft., the output will be 20 mA. As the target distance increases beyond 2 ft., the output will change linearly with distance to 8 ft. where the output will be 4 mA. If the target distance exceeds 8 ft., the output will remain at 4 mA.

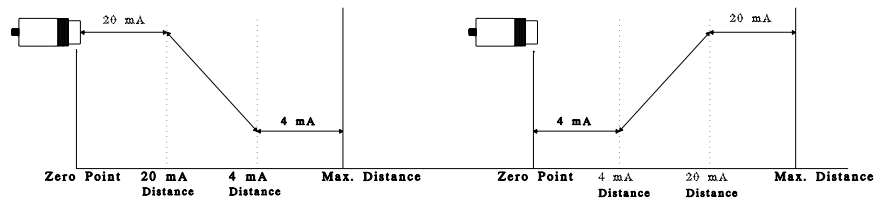

Analog Calibration (No adjustments needed in most applications)

Calibration of the analog signal is accomplished using the 4 mA Calibration and the 20 mA / 5(2.5)V Calibration parameters. To calibrate the output, the sensor must be outputting full scale (20 mA) or minimum scale (4 mA). Increasing or decreasing the value in each parameter will increase or decrease the corresponding mA output value. For example, the 4 mA distance is set to 2.00 ft., and the 20 mA distance is set to 6.00 ft. A target is being detected at 1.7 ft., but the output is 4.3mA instead of 4 mA. The output can be adjusted to 4 mA by decreasing the calibration value in the 4 mA Calibration field until the output is equal to 4 mA. Factory defaults are approximately 8200 for the 4 mA Calibrate, and 41000 for the 20 mA Calibrate.

Trip Point Control

The trip point output has several options to provide a high degree of flexibility. Options are available to allow for presence detection, high and low alarms, and pump control.

Trip Select provides an option of using the potentiometer or the software to determine the trip distances. The options are 0 = manual (potentiometer) and 1 = program. If 1 is selected, the potentiometer is disabled. *NOTE: If a sensor is not equipped with a potentiometer this parameter must be set to the program option.*

Trip Distance: sets the distance from the sensor face to the nearest trip position. (see chart on the following page)

Trip Window: begins at the point of the "Trip Distance", and determines the far trip position. (see chart on the following page)

Trip Type: allows for different trip configurations based on the application need such as presence detection, high and/or low alarms, pump up and pump down. The five options are illustrated in the following chart.

The "**Type 0**" or Near trip setting will activate the trip output when a target comes closer than the trip distance setting (BEGIN). The trip will remain activated when a target is between the Blanking distance and the trip distance. This can be used for presence detection applications, stack height limits or high level alarms.

The "**Type 1**" or Exclusive trip setting will activate the trip when a target is closer than the trip distance setting (BEGIN), or farther than the trip distance plus the trip window distance (END). This setting can be used for both a high and low alarm, or a presence detection application.

The "**Type 2**" Hysteresis Near functions as a pump down control, or as a high alarm with hysteresis to keep the relay from chattering. When the level reaches the BEGIN point, the relay will turn on and remain on until the level drops to the END location. The relay will remain off until the level rises to the BEGIN point at which time the relay will activate again.

The "**Type 3**" or Far activates when the target is beyond the trip distance. This can be used for a low alarm, or fail safe presence detection. For fail safe, the trip is activated when no target is present, but deactivates on detection. If the sensor fails due to power outage, the trip will deactivate providing an alarm function.

The "Type 4" or Inclusive activates when the target is within the trip window. This can be used for various presence detection application.

The "Type 5" or Hysteresis Far, is used for pump up applications, or for a low level alarm with hysteresis function. This is the opposite function of the Type 2.

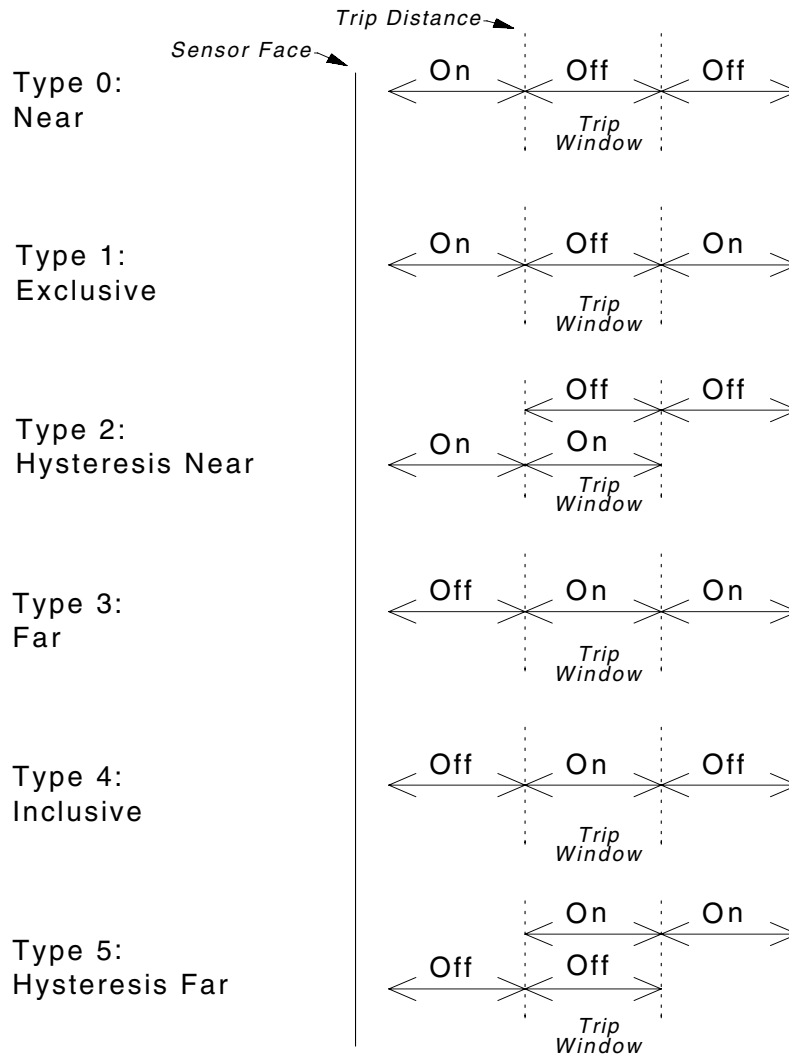



Serial Operation

Sensors with the built-in RS-232, such as the U4466-6429S and U4466-9429S, will communicate at 9600 baud, 8 bit with 1 stop bit and no parity. The sensor will accept an ASCII command and in return send distance and temperature in ASCII. When the sensor receives the SEND command (all capital letters), the sensor will transmit the distance in feet, a comma, the temperature in degrees Celsius, followed by a carriage return and line feed. The distance will be five characters (e.g., 05.25) and the temperature will have a + or - followed by one or two characters (e.g., +22).

Power must be supplied to the sensor at least 5-10 seconds before the sensor is polled, or the sensor may be operated continuously, polling the sensor when required.



• **U4466 200x, 21xx, 24xx & 64xx Series Specifications**

Operating Range 2xxx 1 to 25 feet (0.3 m to 7.62 m) on a hard target
Operating Range 64xx 1 to 30 feet (0.3 m to 9.1 m) on a hard target
Outputs 4-20 mA, NPN Trip Points, (NPN Trips = 300 mA max)
Solid State Relay. (U4466-2002 only; Relay = 130 mA max)
0-2.5 / 0-5 VDC (U4466-6429 only)
Supply Voltage 24 VDC*
Total Current Draw 80 mA @ 24 VDC
Maximum Power Rating . 2.5 Watts
Housing ABS (Surface Mount), PVC (NPT), PC/PET, 150#
PVC Flange (Teflon Faced), PVC w/ 3" SS Tri-Clamp
Transducer Type Ceramic, 69 kHz
Rating ABS Housing NEMA 4X
PVC & PC/PET Housings NEMA 4X
Approvals: CSA Class I Div. 2 groups A, B, C & D (models 2125
and 2225 only)
CSA General Purpose (Models 2002, 2003, 2005, 2122,
2123 & 2223)
Response Time Programmable (20 mS min.)
Resolution 0.1 in. (2.54 mm)
Accuracy $\pm 0.25\%$ of range with no temperature gradient
Operating Temp -40 to 60 °C
Temp. Compensation Internal
Sample Rate Programmable 1-22 Hz
Beam Pattern 9° off axis

*Sensor will operate from 12 to 28 VDC.

*All sensors performance is diminished if less than 24 VDC is applied.

*A minimum of 15 VDC is needed to program the sensor using the RST module.

Dimensions -- in./mm

U4466-200x

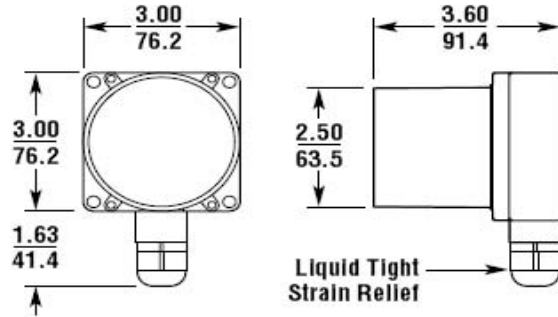

U4466-21xx

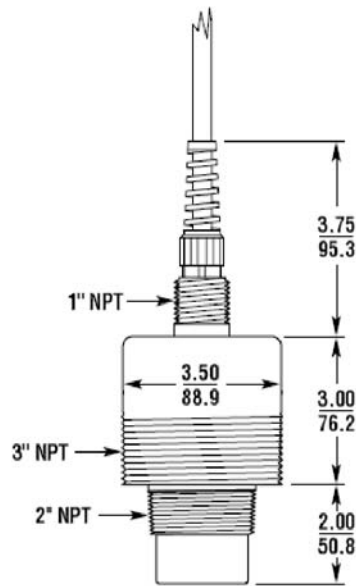

U4466-24xx & U4466-64xx

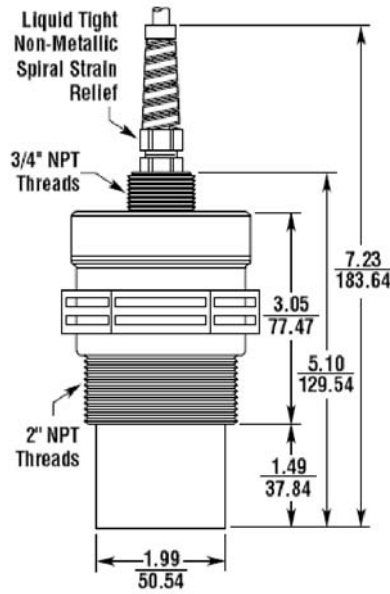



• **U4466 3000 Series Specifications**

Operating Range 31xx 1.25 ft. to 35 ft. (0.38 m to 11.5 m)
Operating Range 34xx 1.25 to 50 ft. (0.4 m to 15.2 m)
Outputs 4-20 mA or 4-20 mA with 2- NPN Trip Points.
(NPN Trips = 300 mA max.)
Supply Voltage 24 VDC*
Total Current Draw 80 mA @ 24 VDC
Maximum Power Rating . 2.5 Watts
Housing PVC (NPT), 150# PVC Flange (Teflon Faced)
Transducer Type Ceramic, 43 kHz
Rating PVC Housing NEMA 4X
Approvals: CSA Class I Div. 2 groups A, B, C & D (models 3135
and 3235 only)
CSA General Purpose (Models 3133 & 3233)
Response Time Programmable (20 mS min.)
Resolution 0.1 in. (2.54 mm)
Accuracy $\pm 0.25\%$ of range with no temp. gradient
Operating Temp -40 to 60 °C
Temp Compensation Internal
Sample Rate Programmable 1-20 Hz
Beam Pattern 9° off axis

*Sensor will operate from 12 to 28 VDC.

*Sensor performance is diminished if less than 24 VDC is applied.

*A minimum of 15 VDC is needed to program the sensor using the RST module.

Dimensions -- in./mm

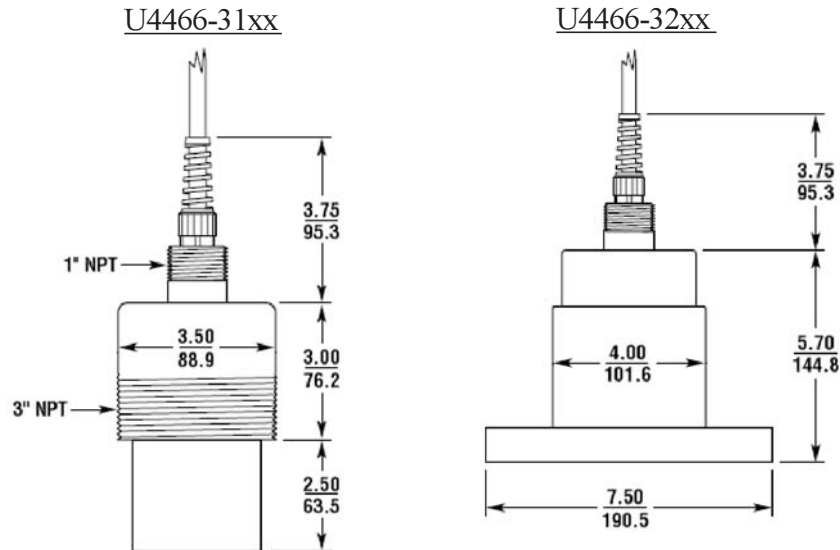

U4466-34xx

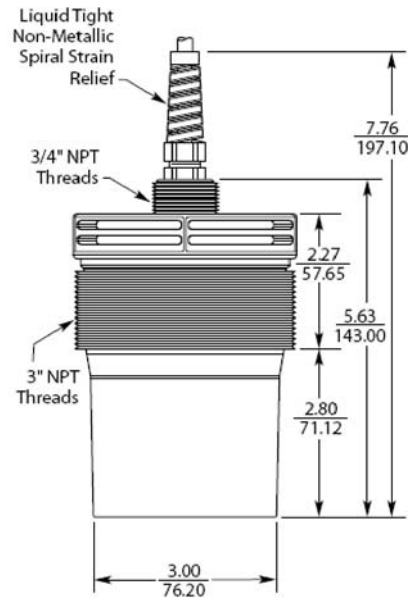



• **U4466-51xx & 5320 Series Specifications**

Operating Range 4 to 79 in. (102 to 2000 mm) on hard target
Outputs 4-20 mA, 4-20 mA NPN Trip Points,(NPN Trips = 300
mA max.)
0-5VDC or 0-2.5VDC
Supply Voltage 24 VDC*
Total Current Draw 80 mA @ 24 VDC
Maximum Power Rating 2.5 Watts
Housing PC/PET, PC/PET w/ 2" SS Tri-Clamp.
Transducer Type Ceramic, 143 kHz
Rating PC/PET Housings NEMA 4X
Approvals: CSA Class I Div. 2 groups A, B, C & D (CSA
approval pending)

Response Time Programmable (20 mS min.)
Resolution 0.1 in. (2.54 mm)
Accuracy $\pm 0.25\%$ of range with no temperature gradient
Operating Temp -40 to 60 °C
Temp. Compensation Internal
Sample Rate Programmable 1-22 Hz
Beam Pattern 9° off axis

*Sensor will operate from 12 to 28 VDC.

*All sensors performance is diminished if less than 24 VDC is applied. U4466-5xx9 models will operate with the same performance down to 12 VDC.

*A minimum of 15 VDC is needed to program the sensor using the RST module.

Dimensions -- in./mm

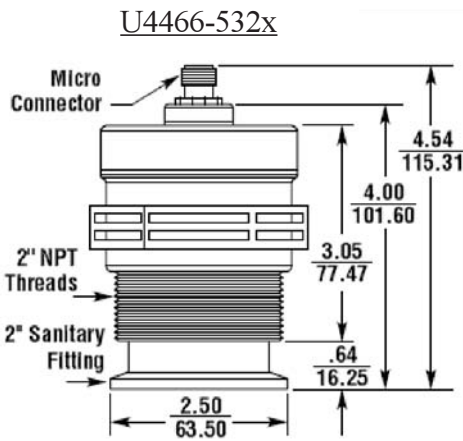
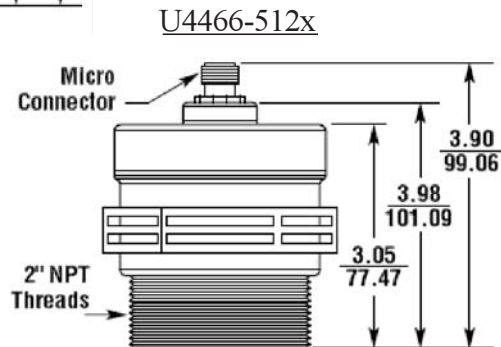
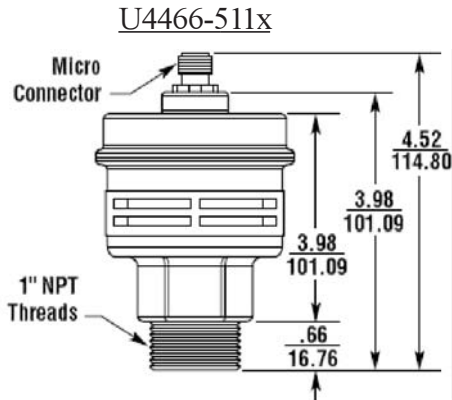

• **U4466-9400 Series Specifications**

- Operating Range5 to 35 feet (0.15 to 10.67 meters) on hard target
- Outputs 4-20 mA, NPN Trip Points,(NPN Trips = 300 mA max.)
0-5VDC or 0-2.5VDC
- Supply Voltage 24 VDC*
- Total Current Draw 75 mA @ 24 VDC
- Maximum Power Rating 2.5 Watts
- Housing PC/PET
- Transducer Type Electrostatic, 50 kHz
- Rating PC/PET Housings NEMA 12
- Approvals: CSA general purpose (CSA approval pending)

- Response Time Programmable (20 mS min.)
- Resolution 0.1 in. (2.54 mm)
- Accuracy ±0.25% of range with no temperature gradient
- Operating Temp -40 to 60 °C
- Temp. Compensation Internal
- Sample Rate Programmable 1-22 Hz
- Beam Pattern 9° off axis

*Sensor will operate from 12 to 28 VDC

*A minimum of 15 VDC is needed to program the sensor using the RST module.

